



SMONTAGOMME AUTOMATICO
TILT-BACK TYRE CHANGER
DEMONTE-PNEUS AUTOMATIQUE



S 222



**DATI
TECNICI****STANDARD
FEATURES****DONNEES
TECHNIQUES****TECHNISCHE
ANGABEN****DATOS
TÉCNICOS****S 222**

Bloccaggio cerchio	Rim clamping	Blocage jante	Felgeneinspannung	Bloqueo llanta	10" - 22"
Diametro max.ruota	Max.wheel diameter	Diamètre maxi.roue	Max.Raddurchmesser	Diámetro máx. rueda	1000 mm (39")
Largh. max. ruota	Max.wheel width	Largeur maxi.roue	Max.Radbreite	Ancho máx. rueda	340 mm (13")
Forza max. cilindro stallonatore	Max. bead-loosener cylinder force	Force vérin décolleur maxi.	Max. Kraft des Wulstabdrückzylinders	Fuerza máx. cilindro destalonador	24700 N
Pressione d'esercizio	Operating pressure	Pression de service	Betriebsdruck	Presión de trabajo	10 bar (145 psi)
Alimentazione	Power supply	Alimentation	Stromzufuhr	Alimentación	230/400 V 3ph
Potenza motore	Motor power	Puissance moteur	Motorleistung	Potencia motor	0,55 kW
Coppia max. mandrino	Max. spindle torque	Couple maxi. mandrin	Maximales Kräftepaar an der Hauptspindel	Par máx. de mandril	1200 Nm
Limitatore pressione gonfiaggio max.	Inflating pressure limiting device max.	Dispositif limiteur de pression de gonflage maxi.	Vorrichtung zur Reifenfülldruck-begrenzung max.	Dispositivo limitador de presión de inflado máx.	3,5 bar (50 psi)
Peso netto	Net weight	Poids net	Nettogewicht	Peso neto	215 kg STD 233 kg GT

The specifications stated on this brochure are not binding, Giuliano S.p.A. reserves the right to change any specification without notice.

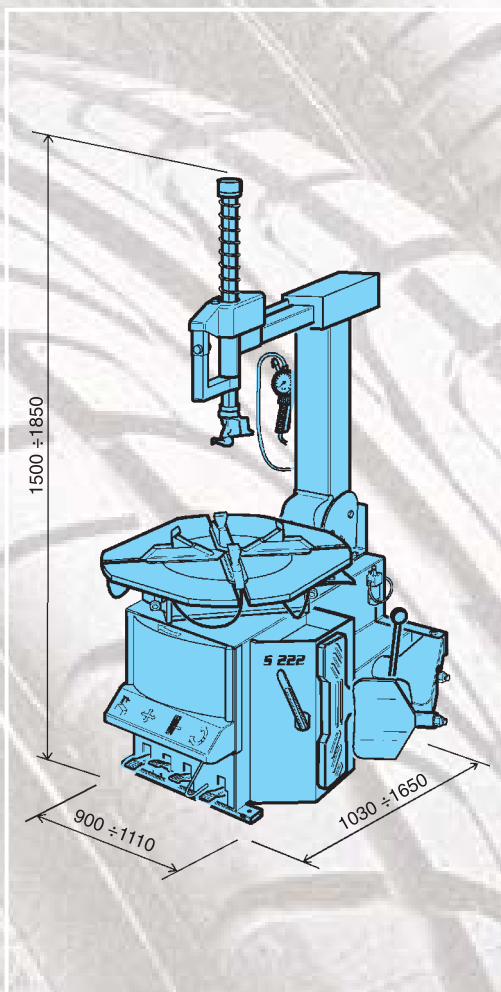
**STANDARD ACCESSORIES****S 222**

TYRE-CHANGERS



WHEEL-BALANCERS



WHEEL ALIGNMENT



LIFTS



TESTING EQUIPMENT



GIULIANO S.p.A. :Via Guerrieri, 6 - 42015 CORREGGIO (RE) ITALY
Tel. +39 0522 731111 - Telefax +39 0522 633109 - E-mail: giuliano@giuliano.it - Internet :www.giuliano.it